

## SEPTAGE ACCEPTANCE UNIT

### Septage, Liquid Treatment Unit for Trucks

#### DESCRIPTION

EQUIP SEP is a machine used to pre-treat wastewater from cesspools, storm drain, industry sewage carried by a tank truck, that have the necessities to be treated before a waste water treatment plant. The machine receive the liquid directly from tank truck by means of a quick connection DN Perrot type. The liquid pass through a perforated screw screen in order to remove all suspended solids; all the filtrated material is transported by the screw on the top of the machine, where it will be washed and compacted before the discharge.

The machine is composed by a reception tank with quick connection, automatic motorized ball valve and a screw screen with compacting zone. Inside the tank is installed a bars sensor level to control the height of the water inside the tank; this, in order to open or close the automatic valve. This system can control the tank truck cycle of discharge automatically. Screening, transport and compacting zone are equipped with a washing system in order to remove all the organic parts from before the discharge.



#### BENEFITS

- ➔ DN Perrot type
- ➔ Automatic motorized valve
- ➔ Integrated washing system

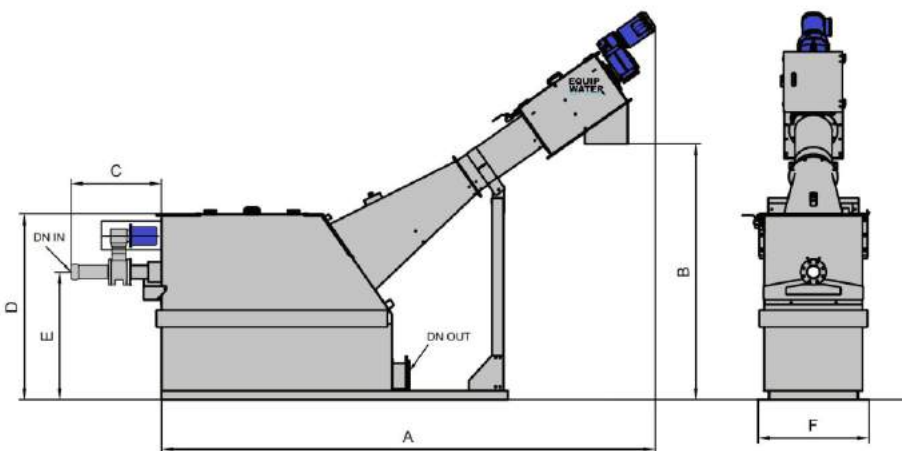

MODEL	Flow m³/h	Dimensions (mm)							
		A	B	C	D	E	F	DN IN	DN OUT
Equip Sep 50	50	3100	1500	780	1300	800	620	100	200
Equip Sep 100	100	4300	2200	780	1600	1105	960	100	200